

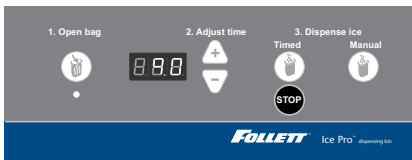

DB1000SA

User friendly Ice Pro control panel!



DB1000SA

Available March 12, 2012

Ice storage bin with automatic agitation to dispense cube ice into ice bags, carts, pails, coolers or Totes™ ice carrier. Exceptional labor-savings, sanitation and safety for foodservice operators and central dispatch locations. Up to 1000 lbs (454 kg) storage capacity.

Labor-saving ice removal

- Eliminates the need to shovel or scoop ice from bin
- Automatic agitation cycle prevents ice from forming bridges – two rotating agitator bars keep ice loose and free flowing
- Foot pedal and push-button actuation standard with dispense rate of up to 120 lbs (55 kg) per minute

Dispenses ice up to 1" (26 mm) square into most carts and containers

- Adjustable bag stand for bag sizes up to 20 lbs (9 kg)
- Standard dispense chute compatible with carts up to 29.5" (750 mm) high
- Dispenses ice into smaller containers such as Totes ice carrier or ice coolers

Easy to clean, easy to use

- Dispensing and agitating components easily removed for cleaning
- Removable, lockable clear window prevents unauthorized access to ice; provides for ice removal in power failures and for maintenance
- Maintenance access from the front and side
- Front assembly removes for transport through narrow doors

Semi-automatic bagging with DB1000SA model

- User-friendly controls with mode selection and variable dispense time
- Blower opens bags automatically for hands-free dispensing
- Bag holder pins for use with wire-wicket ice bags; pins adjust for ice bags 5" to 10" (127 to 254 mm) on center
- Bag six to eight 8 lb bags per minute
- Includes 125 8 lb (3.6 kg) ice bags

Accessories

- Leg extension elevates unit 6.5" (165 mm) for use with taller carts; includes adjustable bag stand to accommodate bag sizes up to 40 lbs (18 kg) (item# ABLEGEXT)
- Reinforced top and drain pan assembly for Vogt icemakers
- 8 lb (3.6 kg) capacity ice bags (item# 00116434)
- 20 lb (9 kg) capacity ice bags (item# 00138370)
- Bostitch P-7 C-ring plier for closing bags (item# 00137711)
- Staples, aluminum blunt-end C-rings (item# 00137729)

JOB: _____

ITEM: _____

U.S. Patent 6,685,053,
6,860,408 & 7,137,271

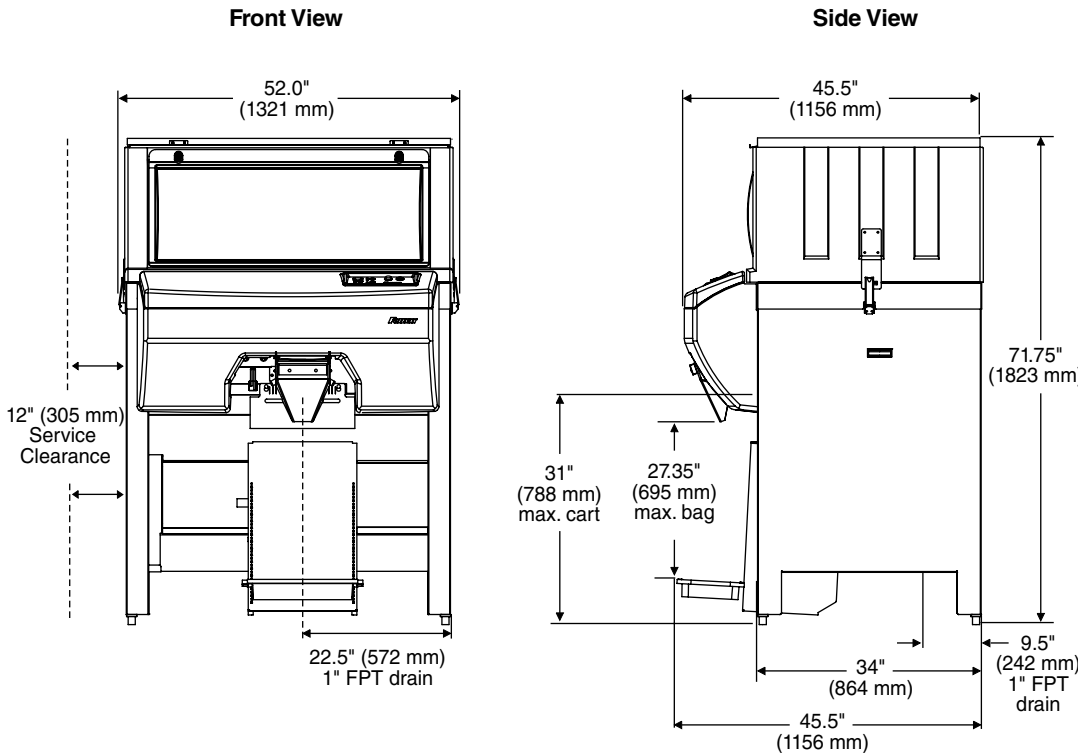

Plug Configuration
NEMA 6-15



General notes

Follett® recommends installation of a floor drain with grate with all ice storage bins.

DB1000SA only: Dispenser shall be equipped with blower function for automatically opening ice bags, timed dispense, and holding pins for bags.

Model Number	Cubic Volume cu ft (m)	Maximum Bin Capacity lb (kg) ¹	Width in (mm)	Depth in (mm) ²	Height in (mm) ³	Required Door Access in (mm)	Approximate Ship Weight lb (kg)
DB1000	33.3 (0.94)	1000 (454)	52.0 (1321)	45.5 (1156)	71.75 (1823)	34.25 (870)	704 (320)
DB1000SA	33.3 (0.94)	1000 (454)	52.0 (1321)	45.5 (1156)	71.75 (1823)	34.25 (870)	704 (320)

Notes:

- 1 Computed on cubic volume of bin. Does not reflect voids that can occur due to pyramiding.
- 2 Dispense assembly removes if necessary for installation access through 36" (915 mm) door opening.
- 3 Special top required for icemakers weighing more than 800 lbs (363 kg). Add 2.125" (54 mm) to height. Contact factory.

Electrical

220 V, 60 Hz, 1 ph, 5 full load amps

Required circuit – 220 V, 60 Hz, 1 ph, 15 amps

Wire in accordance with all local codes.

Specifications

Automatic ice storage and dispensing system to be Follett (DB1000 or DB1000SA) _____ with elevated bin and base. Bin to hold up to 1000 lbs (454 kg) of ice. Dispense rate to be approximately 120 lbs (55 kg) per minute. Two-position ice discharge chute with selector lever allows filling of bags or other containers. Lockable clear inspection window shall have interlock switch to prevent operation if window is removed. Hopper to be constructed of double wall rotationally molded polyethylene insulated with non-CFC polyurethane foam. Storage hopper shall be supported by stainless frame. Heavy-duty agitation system includes two stainless steel agitators and 1/2 HP motor. Dispense auger to be rotationally molded plastic auger driven by 1/4 HP motor. Front assembly removes for installation through narrow doors. Activation of the dispensing function shall be controlled by push-button and foot pedal. Dispenser to be NSF, UL and cUL listed.

Local food regulations vary. Please check with your local authorities for requirements for packaged ice.

Ice Pro and Totes are trademarks of Follett Corporation.

Follett is a registered trademark of Follett Corporation, registered in the US.

Follett reserves the right to change specifications at any time without obligation. Certifications may vary depending on country of origin.